

Installation instructions Voltage transformers installation instructions 14122009.doc/Mla

Voltage transformers for parallel circuits

These instructions concerns the following types: KRV 530 or KRVS 530 -series, KRV 536 or KRVS 536-series, KRV 540 or KRVS540 – series, KRV 545 or KRVS 545 and KRV 550 or KRVS550 - series

Read these instructions before installation

Caution

Only personnel qualifying to work with high voltage equipment and circuits are allowed to do the installation.

Make sure that the circuits are disconnected from the voltage supply and correctly grounded. Never connect or disconnect live circuits. Voltage of primary circuit is lethal.

Make sure that the outer diameter of cable and the diameter of cable insulation correspond to the connector type. Check also that any damage has not occurred for the connectors otherwise do not proceed the installation.

Follow the local instructions for safety precautions or refer to the FAA advisory circular AC150/5340-26 (maintenance of Airport visual Aid Facilities)

Follow also Advisory circular AC150/5370-10 part XI Lighting installations

Always test the installation according to above mentioned documents, local instructions and local electrical codes.

General:

Voltage transformers are single phased transformers used parallel voltage systems. Primary voltage is 230Vac, secondary current is 6,6A ac and power 45W/6,8Vac, 100W/15,2Vac or 200W/30,3Vac, and also customized transformers are available. The transformers together with their connectors are in normal conditions waterproof and can be installed above ground, in all types of pull pits. They can also be directly buried.

Installation

- It is recommendable to keep transformers and connectors above the standing water level.
- Make sure that the transformer is of the type that has been planned for the installation.
- Clean the connectors before connection.

KRV-series:

- 2 Primary T-connectors fits to connectors (FAA) Type I, Class A and B, Style 10 & 3 (e.g. Efla's KD510 series)
- Secondary receptacle (L-823 style 7) fits to connector (FAA) Type II, Class A and B, Style 4 and 5 (e.g. Efla's KD 501 and KD 503 series)

KRVS-series:

- Primary connector (L-823 Style 1) fits to connector (FAA) Type I, Class A and B, Style 12 & 11 (e.g. Efla's KD502 and KD503/R series)
- Secondary receptacle (L-823 style 7) fits to connector (FAA) Type II, Class A and B, Style 4 and 5 (e.g. efla's KD 501 series)

Special attention should be paid to the following matters!

- **Never make connections on a live conductor!**
- **Never bend connectors during connecting or disconnecting!**
- **Secure the primary joints with the enclosed locking device or tape (refer to installation instruction of primary and secondary connectors)!**
- **Whenever the secondary connector is connected, make sure that the connectors are connected correctly (There are two types of inserts)!**

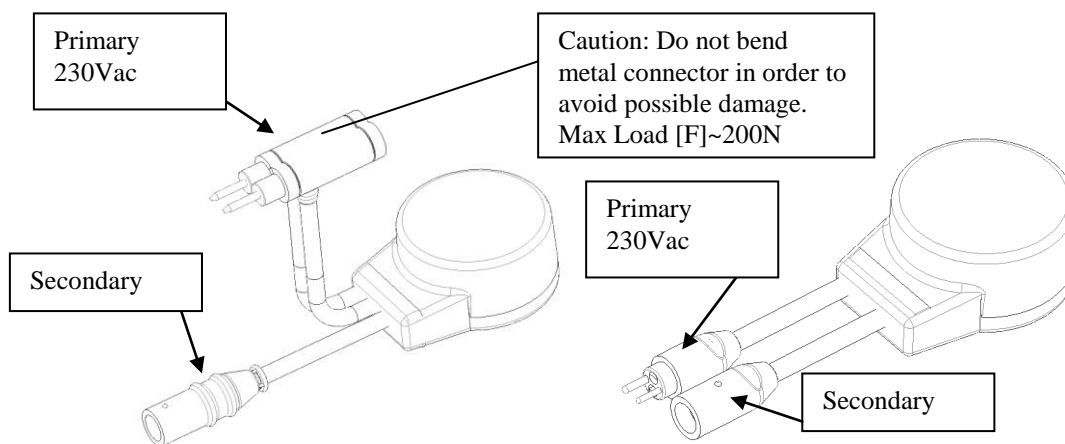

KRV-SERIES VOLTAGE TRANSFORMER

KRVS-SERIES VOLTAGE TRANSFORMER

Liability for defects

This product will perform within the recommended operational ratings when installed and operated in accordance with these instructions. Efla Oy liability is limited to replacement of component parts designed and manufactured by Efla Oy which are proved to be defective in design, workmanship or material. For further details see our conditions of sale NL 92E.